

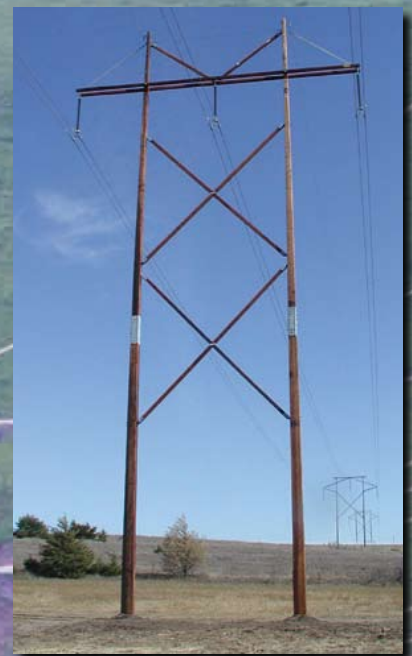

The Ultimate Power of Engineered Laminated Wood

Tangent Poles



**Southern Pine &
Coastal Fir**

30ft - 135ft

**Pole Dimensions,
Weights & Strengths**



1-800-949-3526

www.lwsinc.com

Engineered Designs and Pole Orientation

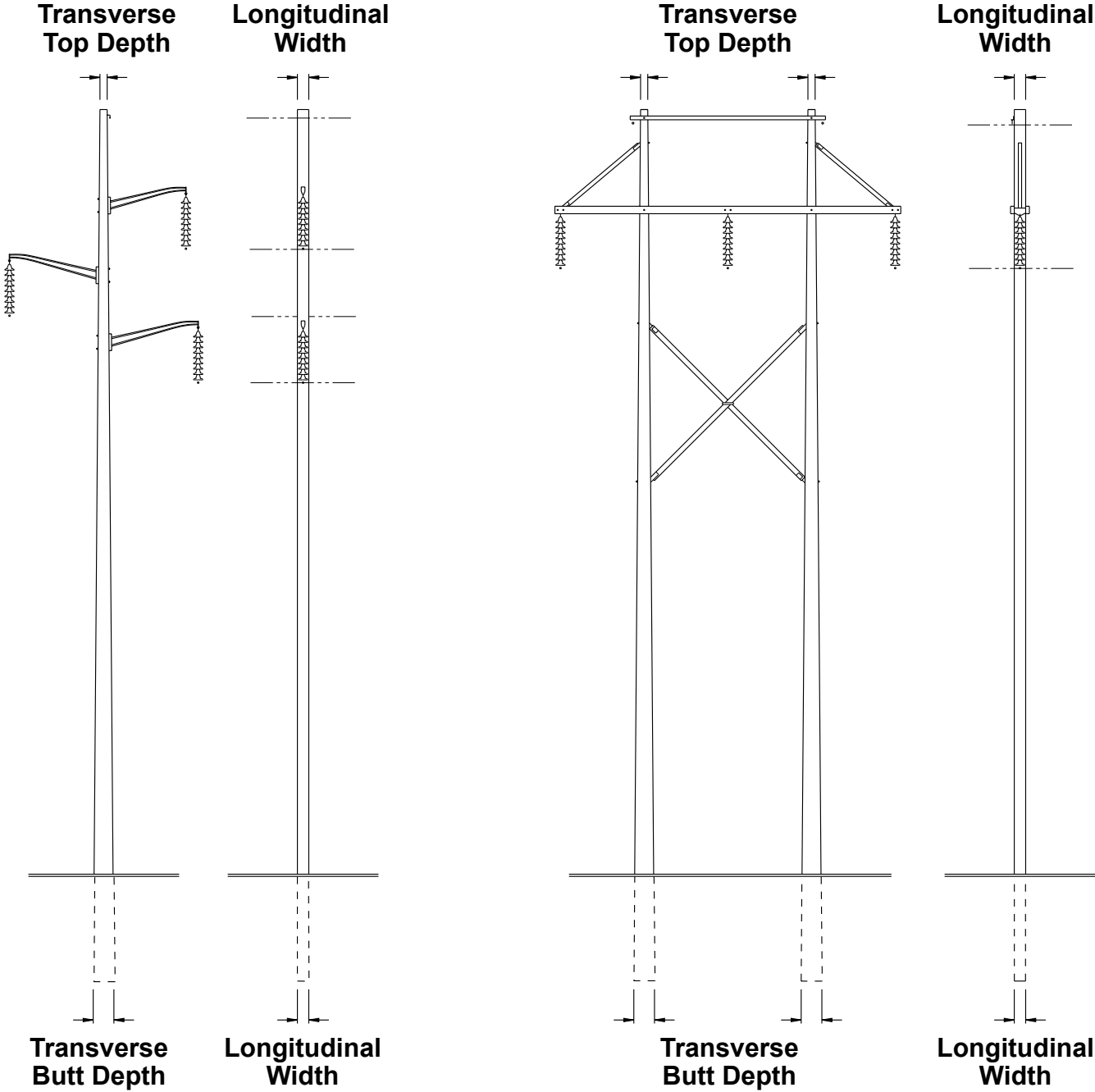

**Complete Structure Kits are Available
by Calling 1-800-949-3526**

Pole Length (Feet)	Pole Class	Long. Width	Transverse			Ultimate Longitudinal Groundline Moment (Ft.-Kips)	Ultimate Transverse Groundline Moment (Ft.-Kips)	Approx. Treated Weight (Lbs.)	
			Top Depth	Butt Depth					
30 Foot	PEL-5-30	6-3/4"	x	5-1/2"	-	9-5/8"	44.9	56.0	490
	PEL-4-30	6-3/4"	x	6"	-	10-1/2"	48.9	66.6	535
	PEL-3-30	6-3/4"	x	6-1/2"	-	11-3/8"	53.0	78.2	580
	PEL-2-30	6-3/4"	x	7"	-	12-1/4"	57.1	90.7	625
	PEL-1-30	6-3/4"	x	7-1/2"	-	13-1/8"	61.2	104.2	670
35 Foot	PEL-5-35	6-3/4"	x	5-1/2"	-	9-5/8"	45.1	56.6	570
	PEL-4-35	6-3/4"	x	6"	-	11-7/8"	55.0	84.1	675
	PEL-3-35	6-3/4"	x	6-1/2"	-	12-3/4"	59.1	97.1	725
	PEL-2-35	6-3/4"	x	7"	-	13-5/8"	63.2	111.1	775
	PEL-1-35	6-3/4"	x	7-1/2"	-	14-1/2"	67.3	126.0	830
40 Foot	PEL-5-40	6-3/4"	x	5-1/2"	-	11"	51.5	73.7	710
	PEL-4-40	6-3/4"	x	6"	-	11-7/8"	55.6	86.1	770
	PEL-3-40	6-3/4"	x	6-1/2"	-	14-1/8"	65.7	120.0	890
	PEL-2-40	6-3/4"	x	7"	-	15"	69.8	135.6	950
	PEL-1-40	6-3/4"	x	7-1/2"	-	15-7/8"	74.0	152.2	1,010
45 Foot	PEL-5-45	8-1/2"	x	5"	-	11-1/2"	84.7	100.0	1,010
	PEL-4-45	8-1/2"	x	5"	-	11-1/2"	84.7	100.0	1,010
	PEL-3-45	8-1/2"	x	5 1/2"	-	13-3/4"	100.8	141.5	1,170
	PEL-2-45	8-1/2"	x	6-1/4"	-	14-3/8"	105.9	156.3	1,260
	PEL-1-45	8-1/2"	x	7"	-	15"	111.1	171.9	1,340
	PEL-H1-45	8-1/2"	x	7-1/2"	-	17-1/4"	127.1	225.1	1,510
	PEL-H2-45	8-1/2"	x	8"	-	18-1/8"	133.7	248.1	1,595
50 Foot	PEL-5-50	8-1/2"	x	5"	-	11-1/2"	85.0	100.6	1,120
	PEL-4-50	8-1/2"	x	5"	-	12-7/8"	94.5	124.3	1,210
	PEL-3-50	8-1/2"	x	5-1/2"	-	13-3/4"	101.1	142.3	1,305
	PEL-2-50	8-1/2"	x	6-1/4"	-	15-3/4"	115.7	186.5	1,490
	PEL-1-50	8-1/2"	x	7"	-	16-3/8"	120.9	203.5	1,585
	PEL-H1-50	8-1/2"	x	7-1/2"	-	18-5/8"	137.0	259.6	1,770
	PEL-H2-50	8-1/2"	x	8"	-	19-1/2"	143.6	284.0	1,870
55 Foot	PEL-5-55	8-1/2"	x	5"	-	12-7/8"	94.7	124.9	1,335
	PEL-4-55	8-1/2"	x	5"	-	14-1/4"	104.2	151.3	1,440
	PEL-3-55	8-1/2"	x	5-1/2"	-	15-1/8"	110.8	171.1	1,540
	PEL-2-55	8-1/2"	x	6-1/4"	-	15-3/4"	116.0	187.4	1,645
	PEL-1-55	8-1/2"	x	7"	-	17-3/4"	130.7	237.5	1,850
	PEL-H1-55	8-1/2"	x	7-1/2"	-	18-5/8"	137.3	260.8	1,950
	PEL-H2-55	8-1/2"	x	8"	-	20-7/8"	153.4	322.1	2,160
60 Foot	PEL-3-60	8-1/2"	x	6"	-	16"	117.7	193.0	1,795
	PEL-2-60	8-1/2"	x	6-1/4"	-	17-1/8"	125.8	220.4	1,905
	PEL-1-60	10-1/4"	x	6-1/4"	-	17-1/8"	182.9	265.8	2,300
	PEL-H1-60	10-1/4"	x	7"	-	17-3/4"	190.4	287.4	2,430
	PEL-H2-60	10-1/4"	x	7-5/8"	-	19-7/8"	212.9	355.3	2,700
	PEL-H3-60	10-1/4"	x	8-1/2"	-	21-3/4"	233.2	422.5	2,970
	PEL-H4-60	10-1/4"	x	9-1/4"	-	22-3/8"	240.7	448.7	3,110
PEL-H5-60	10-1/4"	x	10"	-	24-3/8"	262.1	527.5	3,380	
PEL-H6-60	10-1/4"	x	11"	-	26-1/8"	281.4	603.5	3,650	

E-LAM[®] Southern Pine

Pole Length (Feet)	Pole Class	Long. Width	Transverse		Ultimate Longitudinal Groundline Moment (Ft.-Kips)	Ultimate Transverse Groundline Moment (Ft.-Kips)	Approx. Treated Weight (Lbs.)		
			Top Depth	Butt Depth					
65 Foot	PEL-3-65	8-1/2"	x	6"	-	16"	117.9	193.6	1,940
	PEL-2-65	10-1/4"	x	6"	-	16"	171.5	233.5	2,340
	PEL-1-65	10-1/4"	x	6-1/4"	-	17-1/8"	183.3	266.7	2,490
	PEL-H1-65	10-1/4"	x	7"	-	19-1/8"	204.7	329.8	2,780
	PEL-H2-65	10-1/4"	x	7-5/8"	-	19-7/8"	213.3	356.5	2,925
	PEL-H3-65	10-1/4"	x	8-1/2"	-	21-3/4"	233.6	423.9	3,220
	PEL-H4-65	10-1/4"	x	9-1/4"	-	23-3/4"	255.1	500.8	3,510
	PEL-H5-65	10-1/4"	x	10"	-	25-3/4"	276.5	583.8	3,800
	PEL-H6-65	10-1/4"	x	11"	-	27-1/2"	295.8	663.6	4,100
70 Foot	PEL-3-70	8-1/2"	x	6"	-	16"	118.1	194.2	2,090
	PEL-2-70	10-1/4"	x	6"	-	16"	171.7	234.2	2,520
	PEL-1-70	10-1/4"	x	6-1/4"	-	18-1/2"	197.5	308.1	2,835
	PEL-H1-70	10-1/4"	x	7"	-	19-1/8"	205.0	330.7	3,000
	PEL-H2-70	10-1/4"	x	7-5/8"	-	21-1/4"	227.6	403.2	3,310
	PEL-H3-70	10-1/4"	x	8-1/2"	-	23-1/8"	248.0	474.6	3,625
	PEL-H4-70	10-1/4"	x	9-1/4"	-	25-1/8"	269.4	555.7	3,940
	PEL-H5-70	10-1/4"	x	10"	-	27-1/8"	290.9	642.9	4,255
	PEL-H6-70	10-1/4"	x	11"	-	28-7/8"	310.2	726.3	4,570
75 Foot	PEL-3-75	10-1/4"	x	6"	-	16"	172.0	234.8	2,700
	PEL-2-75	10-1/4"	x	6"	-	17-3/8"	186.0	274.7	2,870
	PEL-1-75	10-1/4"	x	6-1/4"	-	18-1/2"	197.8	309.0	3,040
	PEL-H1-75	10-1/4"	x	7"	-	20-1/2"	219.3	375.9	3,380
	PEL-H2-75	10-1/4"	x	7-5/8"	-	22-5/8"	241.9	452.8	3,710
	PEL-H3-75	10-1/4"	x	8-1/2"	-	24-1/2"	262.3	528.1	4,055
	PEL-H4-75	10-1/4"	x	9-1/4"	-	26-1/2"	283.8	613.4	4,390
	PEL-H5-75	10-1/4"	x	10"	-	27-1/8"	291.3	644.5	4,555
	PEL-H6-75	10-1/4"	x	11"	-	28-7/8"	310.6	728.1	4,895
80 Foot	PEL-3-80	10-1/4"	x	6"	-	16"	172.1	235.3	2,880
	PEL-2-80	10-1/4"	x	6"	-	17-3/8"	186.2	275.3	3,060
	PEL-1-80	10-1/4"	x	6-1/4"	-	19-7/8"	212.1	352.7	3,420
	PEL-H1-80	10-1/4"	x	7"	-	21-7/8"	233.6	423.8	3,780
	PEL-H2-80	10-1/4"	x	7-5/8"	-	22-5/8"	242.2	453.8	3,960
	PEL-H3-80	10-1/4"	x	8-1/2"	-	24-1/2"	262.6	529.3	4,330
	PEL-H4-80	10-1/4"	x	9-1/4"	-	26-1/2"	284.1	614.8	4,690
	PEL-H5-80	10-1/4"	x	10"	-	28-1/2"	305.7	706.3	5,050
	PEL-H6-80	12-1/4"	x	10"	-	28-1/2"	436.6	844.1	6,020
85 Foot	PEL-3-85	10-1/4"	x	6"	-	17-3/8"	186.4	275.9	3,250
	PEL-2-85	10-1/4"	x	6"	-	18-3/4"	200.4	316.9	3,450
	PEL-1-85	10-1/4"	x	6-1/4"	-	19-7/8"	212.3	353.5	3,640
	PEL-H1-85	10-1/4"	x	7"	-	21-7/8"	233.9	424.7	4,020
	PEL-H2-85	10-1/4"	x	7-5/8"	-	24"	256.5	506.2	4,400
	PEL-H3-85	10-1/4"	x	8-1/2"	-	25-7/8"	277.0	585.6	4,780
	PEL-H4-85	10-1/4"	x	9-1/4"	-	27-7/8"	298.5	675.2	5,160
	PEL-H5-85	12-1/4"	x	9-1/8"	-	26-5/8"	407.8	741.6	5,950
	PEL-H6-85	12-1/4"	x	10"	-	28-1/2"	437.0	845.7	6,400

Pole Length (Feet)	Pole Class	Long. Width	Transverse		Ultimate Longitudinal Groundline Moment (Ft.-Kips)	Ultimate Transverse Groundline Moment (Ft.-Kips)	Approx. Treated Weight (Lbs.)	
			Top Depth	Butt Depth				
90 Foot	PEL-3-90	10-1/4" x	6"	-	17-3/8"	186.6	276.4	3,450
	PEL-2-90	12-1/4" x	6"	-	17-3/8"	266.5	330.3	4,120
	PEL-1-90	12-1/4" x	6"	-	20-1/8"	306.7	431.6	4,600
	PEL-H1-90	12-1/4" x	6-1/2"	-	21"	320.6	469.3	4,840
	PEL-H2-90	12-1/4" x	7"	-	23-1/4"	354.5	568.2	5,320
	PEL-H3-90	12-1/4" x	7-3/4"	-	23-7/8"	365.2	601.2	5,570
	PEL-H4-90	12-1/4" x	8-1/2"	-	25-7/8"	396.0	701.1	6,050
	PEL-H5-90	12-1/4" x	9-1/8"	-	28"	423.4	814.1	6,540
	PEL-H6-90	12-1/4" x	10"	-	29-7/8"	457.6	922.8	7,020
95 Foot	PEL-2-95	12-1/4" x	6"	-	18-3/4"	288.0	382.8	4,600
	PEL-1-95	12-1/4" x	6"	-	20-1/8"	308.2	435.7	4,860
	PEL-H1-95	12-1/4" x	6-1/2"	-	22-3/8"	342.4	531.9	5,360
	PEL-H2-95	12-1/4" x	7"	-	23-1/4"	356.2	573.5	5,620
	PEL-H3-95	12-1/4" x	7-3/4"	-	25-1/4"	387.2	671.8	6,130
	PEL-H4-95	12-1/4" x	8-1/2"	-	27-1/4"	418.1	777.5	6,640
	PEL-H5-95	12-1/4" x	9-1/8"	-	29-3/8"	450.6	896.4	7,150
	PEL-H6-95	12-1/4" x	10"	-	31-1/4"	480.0	1,010.5	7,670
100 Foot	PEL-2-100	12-1/4" x	6"	-	18-3/4"	289.2	386.0	4,840
	PEL-1-100	12-1/4" x	6"	-	20-1/8"	309.6	439.3	5,110
	PEL-H1-100	12-1/4" x	6-1/2"	-	22-3/8"	343.9	536.4	5,650
	PEL-H2-100	12-1/4" x	7"	-	24-5/8"	378.2	642.6	6,180
	PEL-H3-100	12-1/4" x	7-3/4"	-	26-5/8"	409.3	746.6	6,720
	PEL-H4-100	12-1/4" x	8-1/2"	-	27-1/4"	419.9	783.9	7,000
	PEL-H5-100	12-1/4" x	9-1/8"	-	29-3/8"	452.6	903.8	7,530
	PEL-H6-100	12-1/4" x	10"	-	31-1/4"	482.0	1,018.8	8,100
105 Foot	PEL-2-105	12-1/4" x	6"	-	20-1/8"	308.6	436.6	5,370
	PEL-1-105	12-1/4" x	6"	-	21-1/2"	328.9	492.8	5,650
	PEL-H1-105	12-1/4" x	6-1/2"	-	22-3/8"	342.8	533.0	5,930
	PEL-H2-105	12-1/4" x	7"	-	24-5/8"	377.0	638.6	6,500
	PEL-H3-105	12-1/4" x	7-3/4"	-	26-5/8"	407.9	741.9	7,060
	PEL-H4-105	12-1/4" x	8-1/2"	-	28-5/8"	438.9	852.5	7,630
	PEL-H5-105	12-1/4" x	9-1/8"	-	30-3/4"	471.5	976.7	8,190
	PEL-H6-105	12-1/4" x	10"	-	32-5/8"	500.8	1,095.5	8,750
110 Foot	PEL-2-110	12-1/4" x	6"	-	20-1/8"	309.8	439.9	5,630
	PEL-1-110	12-1/4" x	6"	-	21-1/2"	330.2	496.6	5,920
	PEL-H1-110	12-1/4" x	6-1/2"	-	23-3/4"	364.6	599.3	6,510
	PEL-H2-110	12-1/4" x	7"	-	26"	398.9	711.0	7,100
	PEL-H3-110	12-1/4" x	7-3/4"	-	28"	430.0	820.0	7,690
	PEL-H4-110	12-1/4" x	8-1/2"	-	30"	461.1	936.2	8,280
	PEL-H5-110	12-1/4" x	9-1/8"	-	30-3/4"	473.3	984.1	8,580
	PEL-H6-110	12-1/4" x	10"	-	34"	532.2	1,190.4	9,470

E-LAM[®] Southern Pine

Pole Length (Feet)	Pole Class	Long. Width	Transverse		Ultimate Longitudinal Groundline Moment (Ft.-Kips)	Ultimate Transverse Groundline Moment (Ft.-Kips)	Approx. Treated Weight (Lbs.)		
			Top Depth	Butt Depth					
115 Foot	PEL-2-115	12-1/4"	x	6"	-	21-1/2"	331.5	500.1	6,200
	PEL-1-115	12-1/4"	x	6"	-	22-7/8"	352.0	560.6	6,500
	PEL-H1-115	12-1/4"	x	6-1/2"	-	23-3/4"	365.9	603.6	6,800
	PEL-H2-115	12-1/4"	x	7"	-	26"	400.4	716.1	7,450
	PEL-H3-115	12-1/4"	x	7-3/4"	-	28"	431.6	825.8	8,050
	PEL-H4-115	12-1/4"	x	8-1/2"	-	30"	462.8	942.8	8,660
	PEL-H5-115	12-1/4"	x	9-1/8"	-	32-1/8"	495.6	1,073.8	9,280
	PEL-H6-115	12-1/4"	x	10"	-	34"	525.1	1,198.6	9,900
120 Foot	PEL-2-120	12-1/4"	x	6"	-	21-1/2"	332.6	503.4	6,500
	PEL-1-120	12-1/4"	x	6"	-	22-7/8"	353.2	564.3	6,800
	PEL-H1-120	12-1/4"	x	6-1/2"	-	25-1/8"	387.8	674.0	7,425
	PEL-H2-120	12-1/4"	x	7"	-	27-3/8"	422.4	792.8	8,070
	PEL-H3-120	12-1/4"	x	7-3/4"	-	29-3/8"	453.7	908.0	8,710
	PEL-H4-120	12-1/4"	x	8-1/2"	-	31-3/8"	484.9	1,030.5	9,360
	PEL-H5-120	12-1/4"	x	9-1/8"	-	33-1/2"	517.9	1,167.5	10,000
	PEL-H6-120	12-1/4"	x	10"	-	35-3/8"	547.5	1,297.5	10,650
125 Foot	PEL-2-125	12-1/4"	x	6"	-	21-1/2"	333.6	506.3	6,730
	PEL-1-125	12-1/4"	x	6"	-	24-1/4"	375.1	632.5	7,400
	PEL-H1-125	12-1/4"	x	6-1/2"	-	25-1/8"	389.1	678.1	7,740
	PEL-H2-125	12-1/4"	x	7"	-	27-3/8"	423.8	797.6	8,410
	PEL-H3-125	12-1/4"	x	7-3/4"	-	29-3/8"	455.1	913.5	9,080
	PEL-H4-125	12-1/4"	x	8-1/2"	-	31-3/8"	486.5	1,036.7	9,760
	PEL-H5-125	12-1/4"	x	9-1/8"	-	33-1/2"	519.5	1,174.5	10,430
	PEL-H6-125	12-1/4"	x	10"	-	35-3/8"	549.2	1,305.2	11,100
130 Foot	PEL-2-130	14-1/4"	x	6"	-	21-1/2"	422.5	572.4	8,140
	PEL-1-130	14-1/4"	x	6"	-	22-7/8"	448.6	641.3	8,550
	PEL-H1-130	14-1/4"	x	6-1/2"	-	25-1/8"	492.5	765.8	9,360
	PEL-H2-130	14-1/4"	x	7"	-	27-3/8"	536.4	900.7	10,180
	PEL-H3-130	14-1/4"	x	7-3/4"	-	29-3/8"	576.2	1,031.9	10,990
	PEL-H4-130	14-1/4"	x	8-1/2"	-	31-3/8"	615.9	1,171.4	11,800
	PEL-H5-130	14-1/4"	x	9-1/8"	-	33-1/2"	657.8	1,327.2	12,620
	PEL-H6-130	14-1/4"	x	10"	-	35-3/8"	695.5	1,475.5	13,430
135 Foot	PEL-2-135	14-1/4"	x	6"	-	22-7/8"	448.8	641.9	8,880
	PEL-1-135	14-1/4"	x	6"	-	24-1/4"	474.9	714.6	9,300
	PEL-H1-135	14-1/4"	x	6-1/2"	-	26-1/2"	518.8	845.4	10,150
	PEL-H2-135	14-1/4"	x	7"	-	27-3/8"	536.6	901.5	10,570
	PEL-H3-135	14-1/4"	x	7-3/4"	-	29-3/8"	576.4	1,032.8	11,410
	PEL-H4-135	14-1/4"	x	8-1/2"	-	31-3/8"	616.2	1,172.4	12,260
	PEL-H5-135	14-1/4"	x	9-1/8"	-	34-3/8"	674.7	1,392.7	13,370
	PEL-H6-135	14-1/4"	x	10"	-	35-3/8"	695.8	1,476.8	13,950

Many other sizes are available to meet special height or loading conditions.



Renewable Resource

E-LAM[®] Coastal Fir

Pole Length (Feet)	Pole Class	Long. Width	Transverse		Ultimate Longitudinal Groundline Moment (Ft.-Kips)	Ultimate Transverse Groundline Moment (Ft.-Kips)	Approx. Treated Weight (Lbs.)	
			Top Depth	Butt Depth				
30 Foot	EL-5-30	6-3/4"	X	5-1/2"	9-1/2"	35.0	45.3	430
	EL-4-30	6-3/4"	X	6"	10-1/2"	38.5	55.2	475
	EL-3-30	6-3/4"	X	6-1/2"	13"	47.0	82.3	560
	EL-2-30	6-3/4"	X	7"	14"	50.7	95.5	605
	EL-1-30	6-3/4"	X	7-1/2"	15"	54.3	109.6	650
35 Foot	EL-5-35	6-3/4"	X	5-1/2"	11"	40.0	59.7	555
	EL-4-35	6-3/4"	X	6"	12"	43.7	71.1	605
	EL-3-35	6-3/4"	X	6-1/2"	13"	47.3	83.4	655
	EL-2-35	6-3/4"	X	7"	15-1/2"	56.0	116.4	755
	EL-1-35	6-3/4"	X	7-1/2"	16-1/2"	59.6	132.1	805
40 Foot	EL-5-40	6-3/4"	X	5-1/2"	12-1/2"	45.6	77.4	690
	EL-4-40	6-3/4"	X	6"	13-1/2"	49.3	90.4	750
	EL-3-40	6-3/4"	X	6-1/2"	14-1/2"	53.0	104.4	805
	EL-2-40	6-3/4"	X	7"	15-1/2"	56.7	119.5	865
	EL-1-40	6-3/4"	X	7-1/2"	18"	65.4	159.3	980
45 Foot	EL-5-45	8-3/4"	X	5-1/2"	11"	68.3	79.7	925
	EL-4-45	8-3/4"	X	6"	12"	74.5	94.9	1,005
	EL-3-45	8-3/4"	X	6-1/2"	13"	80.8	111.3	1,090
	EL-2-45	8-3/4"	X	7"	15-1/2"	95.6	155.9	1,260
	EL-1-45	8-3/4"	X	7"	17"	104.2	185.2	1,340
	EL-H1-45	8-3/4"	X	7-1/4"	18-1/4"	111.6	212.5	1,425
	EL-H2-45	8-3/4"	X	7-3/4"	19-1/4"	117.8	236.8	1,510
50 Foot	EL-5-50	8-3/4"	X	5-1/2"	12-1/2"	77.1	101.6	1,120
	EL-4-50	8-3/4"	X	6"	13-1/2"	83.4	118.6	1,210
	EL-3-50	8-3/4"	X	6-1/2"	14-1/2"	89.6	137.0	1,310
	EL-2-50	8-3/4"	X	7"	15-1/2"	95.8	156.7	1,400
	EL-1-50	8-3/4"	X	7"	17"	104.5	186.3	1,490
	EL-H1-50	8-3/4"	X	7-1/4"	19-3/4"	120.5	248.0	1,680
	EL-H2-50	8-3/4"	X	7-3/4"	20-3/4"	126.8	274.3	1,770
55 Foot	EL-5-55	8-3/4"	X	5-1/2"	12-1/2"	77.3	102.0	1,230
	EL-4-55	8-3/4"	X	6"	13-1/2"	83.5	119.1	1,330
	EL-3-55	8-3/4"	X	6-1/2"	16"	98.5	165.5	1,540
	EL-2-55	8-3/4"	X	7-1/4"	18-1/4"	112.2	214.8	1,740
	EL-1-55	8-3/4"	X	7-1/4"	19-3/4"	120.8	249.3	1,850
	EL-H1-55	8-3/4"	X	7-1/4"	21-1/4"	129.5	286.4	1,950
	EL-H2-55	8-3/4"	X	7-3/4"	22-1/4"	135.8	314.6	2,050
60 Foot	EL-3-60	8-3/4"	X	6-1/2"	16"	98.7	166.2	1,680
	EL-2-60	10-1/4"	X	7-1/4"	16-3/4"	142.3	215.0	2,095
	EI-1-60	10-1/4"	X	7-1/4"	18-1/4"	154.2	252.6	2,225
	EL-H1-60	10-1/4"	X	7-1/4"	19-3/4"	166.2	293.2	2,355
	EL-H2-60	10-1/4"	X	7-3/4"	22-1/4"	186.7	370.2	2,620
	EL-H3-60	10-1/4"	X	8-1/2"	23"	193.6	398.0	2,750
	EL-H4-60	10-1/4"	X	9-1/4"	25-1/4"	212.5	479.2	3,010
	EL-H5-60	10-1/4"	X	10"	26"	219.4	510.8	3,140
EL-H6-60	10-1/4"	X	11"	28"	236.5	593.9	3,400	



E-LAM[®] Coastal Fir

Pole Length (Feet)	Pole Class	Long. Width		Transverse		Ultimate Longitudinal Groundline Moment (Ft.-Kips)	Ultimate Transverse Groundline Moment (Ft.-Kips)	Approx. Treated Weight (Lbs.)
				Top Depth	Butt Depth			
65 Foot	EL-3-65	8-3/4"	X	6-1/2"	17-1/2"	107.6	197.5	1,940
	EL-2-65	10-1/4"	X	7-1/4"	16-3/4"	142.5	215.6	2,270
	EL-1-65	10-1/4"	X	7-1/4"	19-3/4"	166.5	294.3	2,550
	EL-H1-65	10-1/4"	X	7-1/4"	21-1/4"	178.5	338.2	2,695
	EL-H2-65	10-1/4"	X	7-3/4"	22-1/4"	187.1	371.5	2,835
	EL-H3-65	10-1/4"	X	8-1/2"	24-1/2"	206.0	450.3	3,120
	EL-H4-65	10-1/4"	X	9-1/4"	25-1/4"	212.8	480.9	3,260
	EL-H5-65	10-1/4"	X	10"	27-1/2"	231.7	570.0	3,545
	EL-H6-65	10-1/4"	X	11"	29"	244.9	636.8	3,780
70 Foot	EL-3-70	8-3/4"	X	6-1/2"	17-1/2"	107.7	198.1	2,085
	EL-2-70	10-1/4"	X	7-1/4"	18-1/4"	154.7	254.2	2,595
	EL-1-70	10-1/4"	X	7-1/4"	19-3/4"	166.7	295.2	2,750
	EL-H1-70	10-1/4"	X	7-1/4"	21-1/4"	178.8	339.2	2,900
	EL-H2-70	10-1/4"	X	7-3/4"	23-3/4"	199.4	422.0	3,205
	EL-H3-70	10-1/4"	X	8-1/2"	24-1/2"	206.3	451.7	3,360
	EL-H4-70	10-1/4"	X	9-1/4"	26-3/4"	225.2	538.3	3,665
	EL-H5-70	10-1/4"	X	10"	29"	244.1	632.5	3,970
	EL-H6-70	10-1/4"	X	11"	31"	261.3	724.8	4,275
75 Foot	EL-3-75	10-1/4"	X	6-1/2"	17-1/2"	148.0	232.6	2,620
	EL-2-75	10-1/4"	X	7-1/4"	18-1/4"	154.9	254.8	2,780
	EL-1-75	10-1/4"	X	7-1/4"	21-1/4"	179.0	340.2	3,110
	EL-H1-75	10-1/4"	X	7-1/4"	22-3/4"	191.0	387.5	3,270
	EL-H2-75	10-1/4"	X	7-3/4"	23-3/4"	199.7	423.2	3,435
	EL-H3-75	10-1/4"	X	8-1/2"	26"	218.6	507.3	3,760
	EL-H4-75	10-1/4"	X	9-1/4"	28-1/4"	237.6	599.0	4,090
	EL-H5-75	10-1/4"	X	10"	30-1/2"	256.5	698.3	4,415
	EL-H6-75	10-1/4"	X	11"	32-1/2"	273.7	795.2	4,740
80 Foot	EL-3-80	10-1/4"	X	6-1/2"	17-1/2"	148.2	233.2	2,790
	EL-2-80	10-1/4"	X	7-1/4"	19-3/4"	167.1	296.6	3,140
	EL-1-80	10-1/4"	X	7-1/4"	21-1/4"	179.2	341.0	3,315
	EL-H1-80	10-1/4"	X	7-1/4"	22-3/4"	191.3	388.4	3,490
	EL-H2-80	10-1/4"	X	7-3/4"	25-1/4"	212.0	477.0	3,835
	EL-H3-80	10-1/4"	X	8-1/2"	27-1/2"	230.9	566.1	4,185
	EL-H4-80	10-1/4"	X	9-1/4"	28-1/4"	237.8	600.4	4,360
	EL-H5-80	10-1/4"	X	10"	30-1/2"	256.8	700.0	4,710
	EL-H6-80	12-1/4"	X	11"	29-1/2"	357.0	792.2	5,625
85 Foot	EL-3-85	10-1/4"	X	6-1/2"	19"	160.4	273.2	3,150
	EL-2-85	10-1/4"	X	7-1/4"	19-3/4"	167.3	297.2	3,335
	EL-1-85	10-1/4"	X	7-1/4"	22-3/4"	191.5	389.3	3,705
	EL-H1-85	10-1/4"	X	7-1/4"	24-1/4"	203.6	440.0	3,890
	EL-H2-85	10-1/4"	X	7-3/4"	25-1/4"	212.2	478.1	4,075
	EL-H3-85	10-1/4"	X	8-1/2"	27-1/2"	231.2	567.4	4,445
	EL-H4-85	10-1/4"	X	9-1/4"	29-3/4"	250.2	664.4	4,820
	EL-H5-85	12-1/4"	X	10"	29"	350.0	761.4	5,755
	EL-H6-85	12-1/4"	X	11"	31"	374.6	872.4	6,200

E-LAM® Coastal Fir

Pole Length (Feet)	Pole Class	Long. Width	Transverse		Ultimate Longitudinal Groundline Moment (Ft.-Kips)	Ultimate *Transverse Groundline Moment (Ft.-Kips)	Approx. Treated Weight (Lbs.)	
			Top Depth	Butt Depth				
90 Foot	EL-3-90	12-1/4"	X	6-1/2"	19"	160.6	273.7	3,335
	EL-2-90	12-1/4"	X	7-1/4"	19-3/4"	239.2	355.9	4,220
	EL-1-90	12-1/4"	X	7-1/4"	21-1/4"	256.5	409.2	4,455
	EL-H1-90	12-1/4"	X	7-1/4"	22-3/4"	273.8	466.2	4,690
	EL-H2-90	12-1/4"	X	7-3/4"	25-1/4"	303.4	572.5	5,160
	EL-H3-90	12-1/4"	X	8-1/2"	26"	313.3	610.2	5,395
	EL-H4-90	12-1/4"	X	9-1/4"	28-1/4"	340.4	720.5	5,860
	EL-H5-90	12-1/4"	X	10"	30-1/2"	367.5	840.0	6,330
95 Foot	EL-H6-90	12-1/4"	X	11"	32-1/2"	392.2	956.4	6,800
	EL-2-95	12-1/4"	X	7-1/4"	19-3/4"	240.3	359.0	4,455
	EL-1-95	12-1/4"	X	7-1/4"	21-1/4"	257.7	413.0	4,705
	EL-H1-95	12-1/4"	X	7-1/4"	24-1/4"	292.5	532.1	5,195
	EL-H2-95	12-1/4"	X	7-3/4"	25-1/4"	304.9	578.1	5,445
	EL-H3-95	12-1/4"	X	8-1/2"	27-1/2"	332.2	686.1	5,940
	EL-H4-95	12-1/4"	X	9-1/4"	29-3/4"	359.4	803.3	6,435
	EL-H5-95	12-1/4"	X	10"	30-1/2"	369.3	847.9	6,680
100 Foot	EL-H6-95	12-1/4"	X	11"	32-1/2"	394.0	965.3	7,175
	EL-2-100	12-1/4"	X	7-1/4"	21-1/4"	258.8	416.4	4,950
	EL-1-100	12-1/4"	X	7-1/4"	22-3/4"	276.3	474.7	5,210
	EL-H1-100	12-1/4"	X	7-1/4"	24-1/4"	293.8	536.8	5,470
	EL-H2-100	12-1/4"	X	7-3/4"	26-3/4"	323.7	651.8	5,990
	EL-H3-100	12-1/4"	X	8-1/2"	27-1/2"	333.6	692.0	6,255
	EL-H4-100	12-1/4"	X	9-1/4"	29-3/4"	361.0	810.3	6,770
	EL-H5-100	12-1/4"	X	10"	32"	388.4	937.8	7,295
105 Foot	EL-H6-100	12-1/4"	X	11"	34"	413.2	1061.5	7,815
	EL-2-105	12-1/4"	X	7-1/4"	21-1/4"	258.0	413.8	5,195
	EL-1-105	12-1/4"	X	7-1/4"	22-3/4"	275.4	471.7	5,470
	EL-H1-105	12-1/4"	X	7-1/4"	24-1/4"	292.9	533.3	5,745
	EL-H2-105	12-1/4"	X	7-3/4"	26-3/4"	322.7	647.5	6,290
	EL-H3-105	12-1/4"	X	8-1/2"	29"	350.0	761.6	6,835
	EL-H4-105	12-1/4"	X	9-1/4"	31-1/4"	377.3	885.0	7,385
	EL-H5-105	12-1/4"	X	10"	33-1/2"	404.6	1017.7	7,930
110 Foot	EL-H6-105	12-1/4"	X	11"	35-1/2"	429.3	1146.1	8,475
	EI-2-110	12-1/4"	X	7-1/4"	22-3/4"	276.5	475.3	5,730
	EI-1-110	12-1/4"	X	7-1/4"	24-1/4"	294.0	537.6	6,015
	EL-H1-110	12-1/4"	X	7-1/4"	25-3/4"	311.6	603.6	6,305
	EL-H2-110	12-1/4"	X	7-3/4"	28-1/4"	341.5	725.3	6,875
	EL-H3-110	12-1/4"	X	8-1/2"	29"	351.4	767.7	7,165
	EL-H4-110	12-1/4"	X	9-1/4"	31-1/4"	378.8	892.1	7,735
	EL-H5-110	12-1/4"	X	10"	35"	423.7	1116.3	8,595
	EL-H6-110	12-1/4"	X	11"	37"	448.5	1251.0	9,165



E-LAM[®] Coastal Fir

Pole Length (Feet)	Pole Class	Long. Width	Transverse		Ultimate Longitudinal Groundline Moment (Ft.-Kips)	Ultimate *Transverse Groundline Moment (Ft.-Kips)	Approx. Treated Weight (Lbs.)	
			Top Depth	Butt Depth				
115 Foot	EL-2-115	12-1/4"	X	7-1/4"	24-1/4"	295.1	541.4	6,290
	EL-1-115	12-1/4"	X	7-1/4"	25-3/4"	312.7	608.1	6,590
	EL-H1-115	12-1/4"	X	7-1/4"	27-1/4"	330.4	678.6	6,890
	EL-H2-115	12-1/4"	X	7-3/4"	29-3/4"	360.4	807.9	7,490
	EL-H3-115	12-1/4"	X	8-1/2"	30-1/2"	370.3	852.6	7,785
	EL-H4-115	12-1/4"	X	9-1/4"	32-3/4"	397.8	983.9	8,385
	EL-H5-115	12-1/4"	X	10"	35"	425.3	1124.6	8,985
	EL-H6-115	12-1/4"	X	11"	37"	450.2	1260.0	9,585
120 Foot	EL-2-120	12-1/4"	X	7-1/4"	24-1/4"	296.0	545.0	6,565
	EL-1-120	12-1/4"	X	7-1/4"	25-3/4"	313.8	612.2	6,875
	EL-H1-120	12-1/4"	X	7-1/4"	28-3/4"	349.2	758.4	7,500
	EL-H2-120	12-1/4"	X	7-3/4"	29-3/4"	361.7	813.5	7,815
	EL-H3-120	12-1/4"	X	8-1/2"	32"	389.3	942.3	8,440
	EL-H4-120	12-1/4"	X	9-1/4"	34-1/4"	416.8	1080.5	9,065
	EL-H5-120	12-1/4"	X	10"	36-1/2"	444.4	1228.1	9,690
	EL-H6-120	12-1/4"	X	11"	38-1/2"	469.4	1369.9	10,310
125 Foot	EL-2-125	12-1/4"	X	7-1/4"	24-1/4"	296.9	548.3	6,835
	EL-1-125	12-1/4"	X	7-1/4"	25-3/4"	314.7	616.0	7,165
	EL-H1-125	12-1/4"	X	7-1/4"	28-3/4"	350.4	763.3	7,810
	EL-H2-125	12-1/4"	X	7-3/4"	29-3/4"	362.9	818.7	8,140
	EL-H3-125	12-1/4"	X	8-1/2"	32"	390.5	948.2	8,790
	EL-H4-125	12-1/4"	X	9-1/4"	34-1/4"	418.2	1087.3	9,440
	EL-H5-125	12-1/4"	X	10"	36-1/2"	445.8	1235.8	10,090
	EL-H6-125	12-1/4"	X	11"	38-1/2"	470.8	1378.3	10,740
130 Foot	EL-2-130	14-1/4"	X	7-1/4"	24-1/4"	396.0	609.6	8,270
	EL-1-130	14-1/4"	X	7-1/4"	25-3/4"	419.6	680.4	8,670
	EL-H1-130	14-1/4"	X	7-1/4"	27-1/4"	443.2	754.9	9,060
	EL-H2-130	14-1/4"	X	7-3/4"	29-3/4"	483.5	890.7	9,850
	EL-H3-130	14-1/4"	X	8-1/2"	32"	520.4	1024.3	10,630
	EL-H4-130	14-1/4"	X	9-1/4"	34-1/4"	557.3	1166.7	11,420
	EL-H5-130	14-1/4"	X	10"	36-1/2"	594.2	1317.8	12,210
	EL-H6-130	14-1/4"	X	11"	38-1/2"	627.7	1462.5	13,000
135 Foot	EL-2-135	14-1/4"	X	7-1/4"	25-3/4"	419.8	681.0	9,000
	EL-1-135	14-1/4"	X	7-1/4"	27-1/4"	443.4	755.5	9,410
	EL-H1-135	14-1/4"	X	7-1/4"	28-3/4"	467.0	833.7	9,820
	EL-H2-135	14-1/4"	X	7-3/4"	29-3/4"	483.7	891.5	10,230
	EL-H3-135	14-1/4"	X	8-1/2"	33-1/2"	544.2	1115.2	11,450
	EL-H4-135	14-1/4"	X	9-1/4"	35-3/4"	581.1	1263.4	12,270
	EL-H5-135	14-1/4"	X	10"	38"	618.1	1420.1	13,090
	EL-H6-135	14-1/4"	X	11"	41-1/2"	675.1	1679.8	14,310

Many other sizes are available to meet special height or loading conditions.



Renewable Resource

Installation Recommendations

Installing E-LAM[®] Tangent, Guyed Angle and Dead End Laminated Wood Structures

Identification of Poles

Each E-LAM[®] pole is tagged with the class and length on the face and the butt. If a variety of poles are required on a project, make sure the appropriate pole is spotted at the correct structure location. Additionally, poles of the same class may be drilled for different structures, and verification of structure types should also be confirmed.

Lifting

All poles are identified with "BP" on the face of the width (constant dimension) to identify the approximate balance point before any framing materials are added. The approximate weight of the treated pole will also be located at this point. The poles should be lifted with a steel choker or gut line rather than a flat nylon strap. The choker will slightly indent the edges on the rounded corners insuring a firm hold.



Handling

Poles can be handled just like any other wood pole. If rotation is required to bisect the angle, a regular cant hook for round poles can be used. Any field drilling and preservative treatment application should be consistent with the user's accepted practices for wood products.

These are general recommendations and in no way should be given precedence when they come in conflict with an individual company's accepted and established working practices.

Setting Recommendations

Auger hole to diameter and depth as recommended by LWS. Generally, E-LAM[®] tangent poles should be set to a depth of 10% + 2 ft. (unless soil type and / or load conditions require additional depth - contact LWS for recommended setting depth, hole size and any other options such as foundation systems).

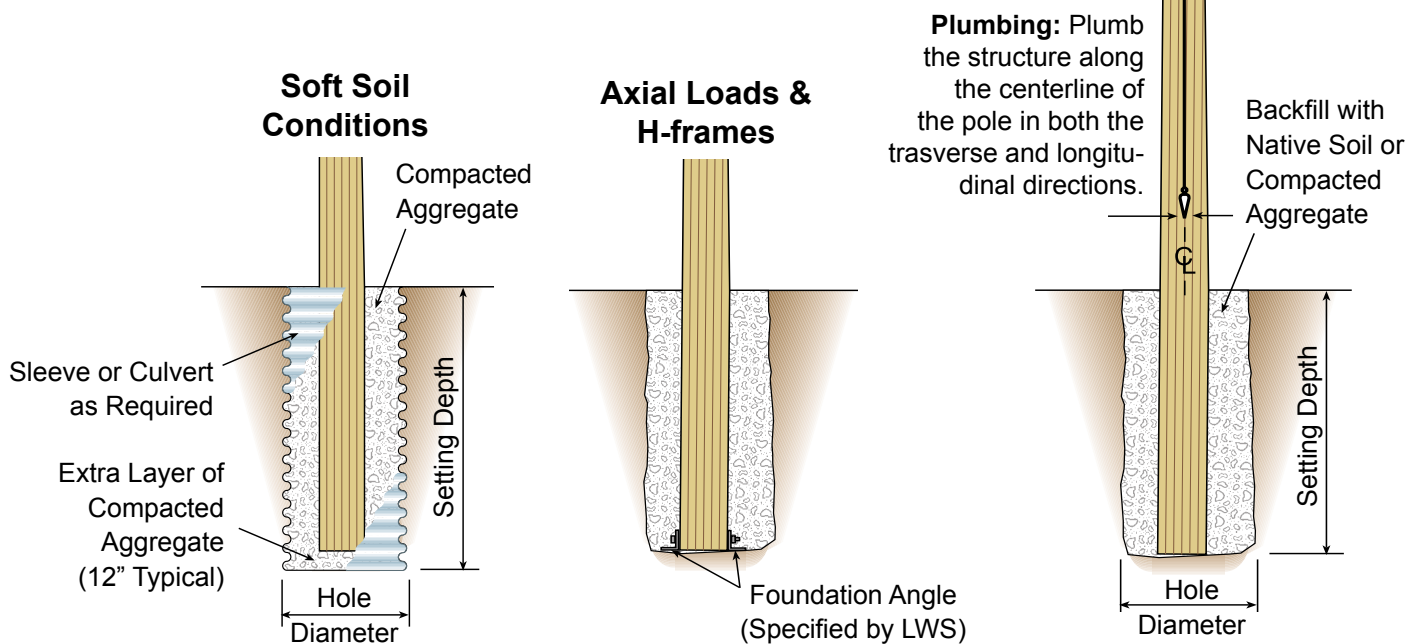

Preservative Treatment of E-LAM® Poles

All poles are treated in accordance with AWWPA specification C1, C4, M2, and especially C28. The most common treatment is penta & oil. CCA and copper naphthenate can also be used upon request.

Standard Groundline Deep Boring for Southern Pine & Coastal Fir E-LAM Poles (Prior to Treatment)

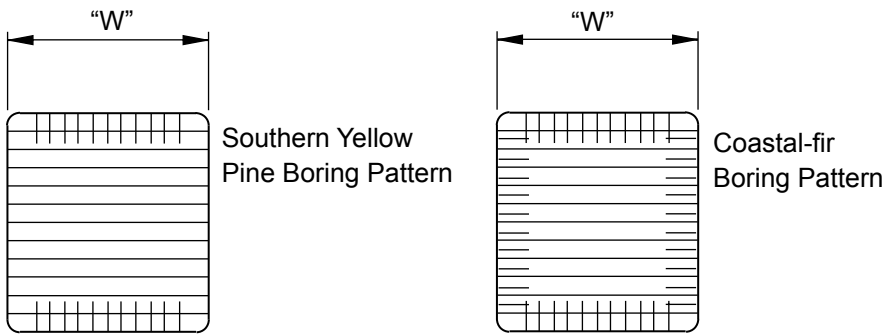

Typical treatment penetration at groundline.

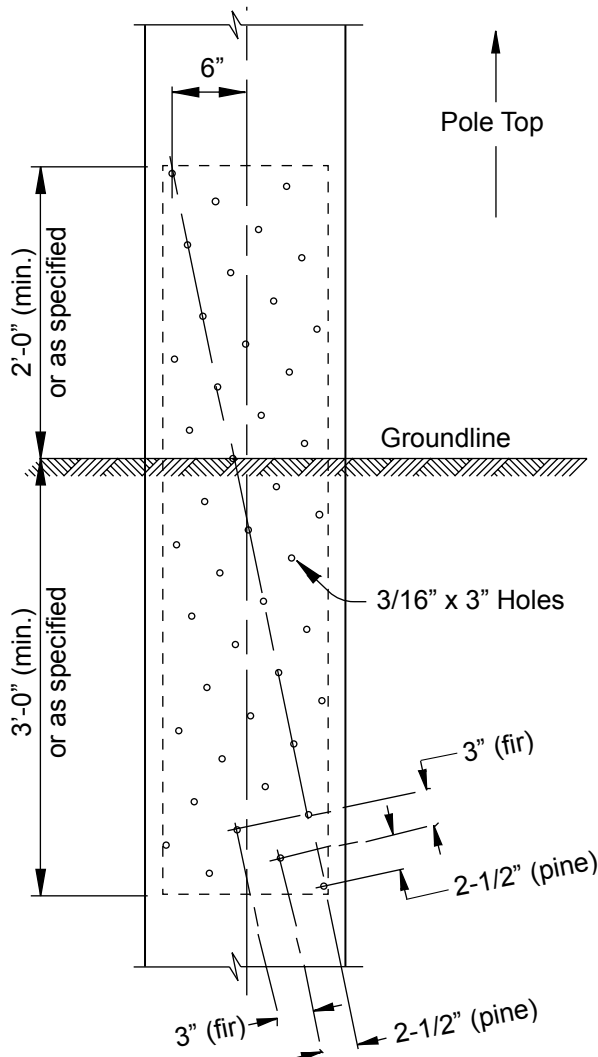

Groundline deep boring.

Hardware for E-LAM® Poles

Pole Shims for Post Insulators

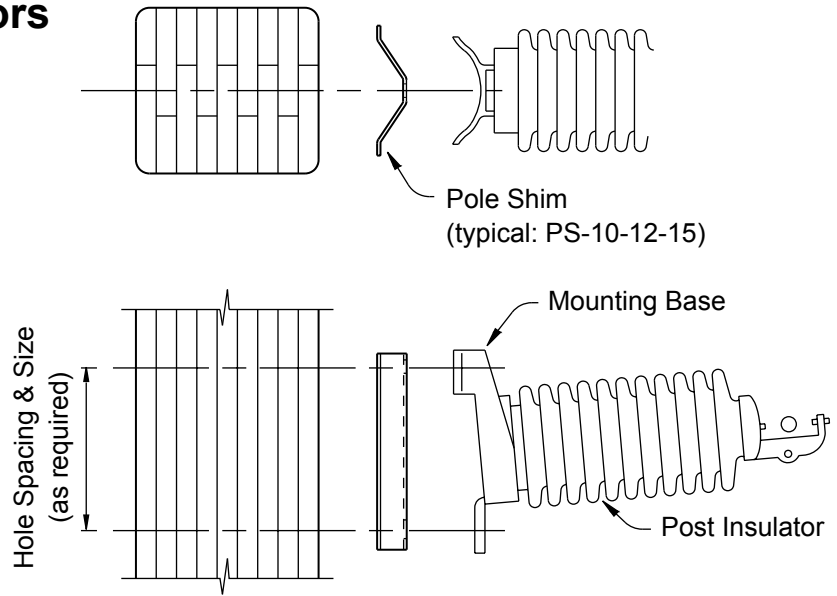
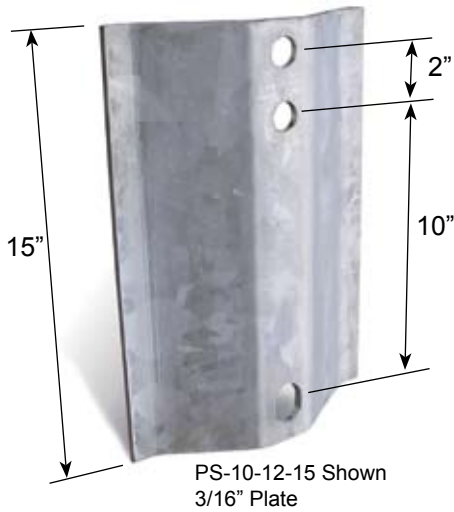

Pole Splice Assemblies

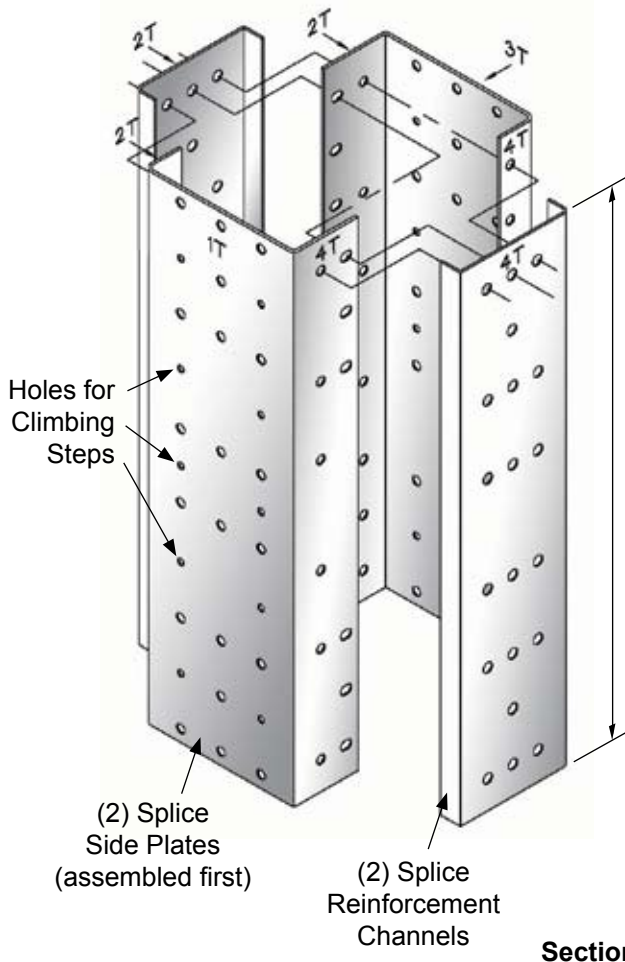

Match "1T" Tag on Pole with "1T" Stamp on Back Side of Splice Plate Assembly

Pole Depth (tapered)

Pole Width (constant)

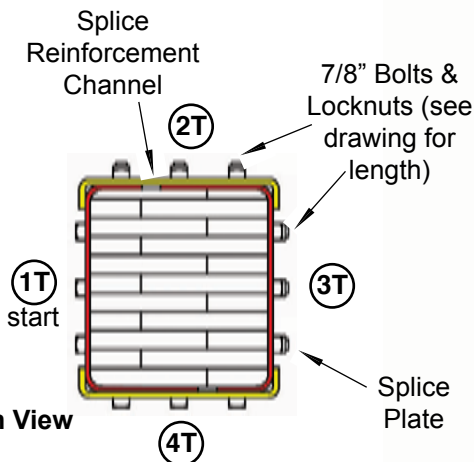

Hardware for E-LAM[®] Poles

Dead End & Guying Hardware

Dead End Tee

Ordering Example:
DET - FD - *

- * 13 for 3/4" Bolts
- * 15 for 7/8" Bolts

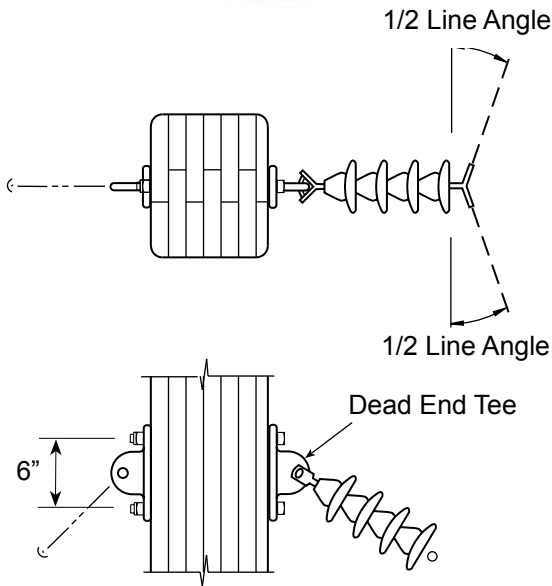
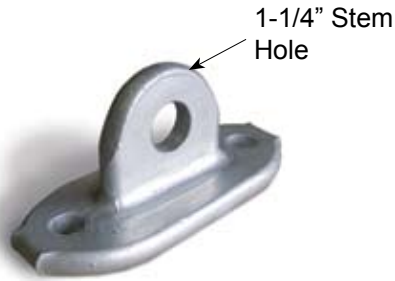

Conductor Dead End & Guying Plate

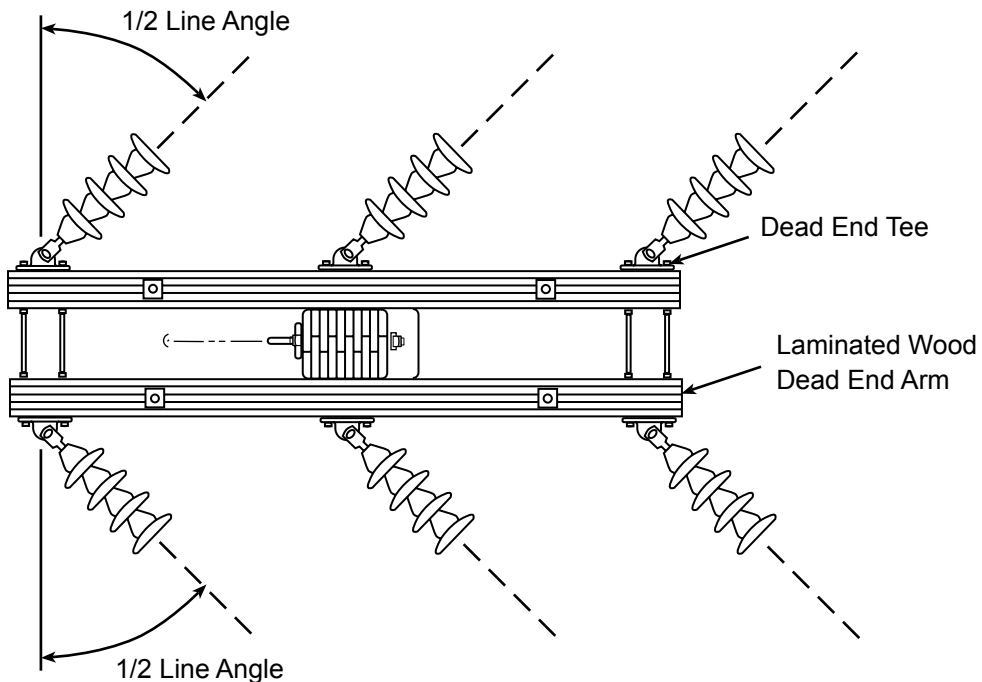
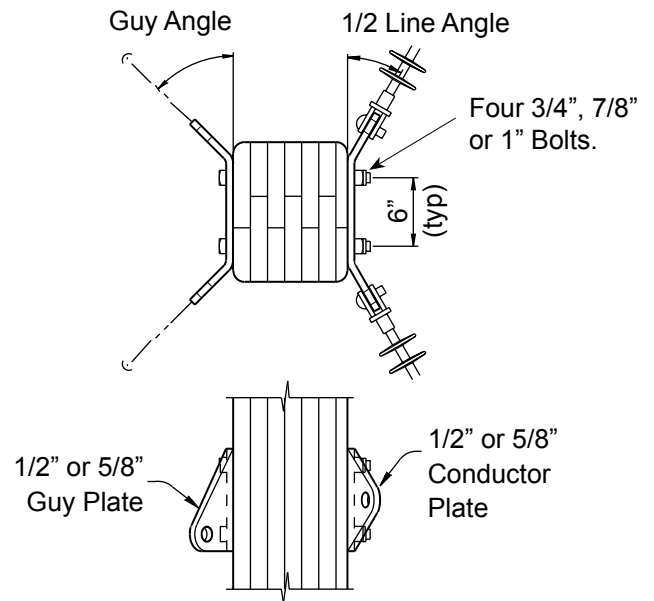

Tangent Pole Applications



Double Circuit 161kV with
Distribution Underbuild



165 ft. 345kV
H-frame



115kV Tangent
with 800 ft. Spans

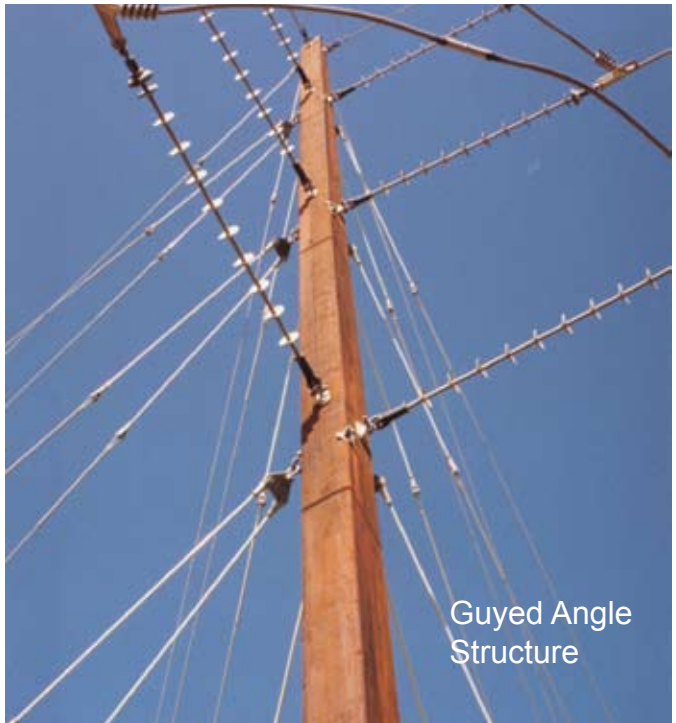

Guyed Angle
Structure

E-LAM[®] Has Been Fully Tested With A Proven History!



Laminated poles are much more aesthetically pleasing than steel or concrete poles.



E-LAM[®] has been fully tested by certified independent labs.



E-LAM[®] is the only engineered pole which can be climbed with hooks and drilled with standard tools.



Laminated Poles have out performed other wood & steel poles for over 40 years.



Laminated Wood Systems, Inc.

1327 285th Road Seward, Nebraska 68434

800-949-3526 www.lwsinc.com



Renewable Resource

©2007 LWS, Inc PEL1 LWS 09-07