

# PRS

## Pole Reclassification System<sup>®</sup>

with Patented Features

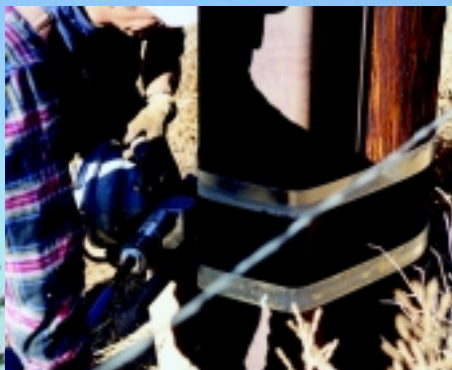

- Reinforce and reclassify existing poles
- Increase pole strengths by three or more classes
- Eliminate the cost of expensive pole change-outs
- Install while the line remains in service - ***MUST be performed by qualified line workers using approved methods***
- Properly transfers the additional load to the soil

# LWS

Laminated Wood Systems, Inc.

# Are your existing poles loaded? The PRS Pole Reclassification

- **The PRS system is a safe and economical way to strengthen existing structures which are overloaded or may become overloaded with the addition of:**
  - Underbuilds
  - Cable TV
  - Phone Cables
  - Fiber Optics**OR The New NESC Extreme Wind Load Requirements**
- **Optimize revenues from existing pole plant assets**
- **Application for distribution and transmission structures available**
- **Portable tools and climbing ladders for easy back-lot installations**
- **Minimal equipment and man power required**



# Added beyond their capacity? PRS Pole Reclassification System® is your solution.

The PRS Pole Reclassification System® from Laminated Wood Systems enables you to reinforce and reclassify existing poles by three or more classes. The PRS system is an economical way to strengthen and extend the life of existing poles without the cost of expensive pole change outs. In most cases, the PRS system can be installed while the line remains in service.\* The PRS is available in galvanized, self-weathering or painted steel.

**\*Installation MUST be performed by qualified line workers using approved methods**





# Installing the PRS System

## STEP 1

The PRS lower steel unit is driven to the specified depth using a pull down winch and an air hammer (standard PoleEnforcer® tools).

*Adds strength to the lower pole section and to the structure foundation.*



## STEP 2

The PRS upper steel unit is placed over the lower unit and temporarily secured.

*Adds strength to the pole to a height where the pole can support the load (based on ANSI 05.1 minimum dimensions).*



## STEP 3

The PRS upper steel unit is then cross bolted to the pole. This can either be done from a bucket truck or by using working ladders attached to the ladder clips (ideal for backyard working applications.)



## STEP 4

The installation is completed by banding the PRS upper unit to the PRS lower driven unit. This "lap" connection allows for movement of the pole and maintains proper transfer of the increased load to the soil.

***Line Crews Can Typically Install Up to 10 PRS Units Per Day!\****

\*The actual number of installations can be affected by soil type, accessibility and terrain.

**1-800-949-3526**

**www.lwsinc.com**

# Complete Material, Driving Systems and Tool Kits Available



Pneumatic and drop-weight driving systems are available as well as a full line of specialized tools. Payback on the initial tool cost is realized after only a few installations.

PRS steel members can be easily installed in most soil conditions by a crew of two. Typical installations take less than one hour from start to finish.

## **PE90PDS Complete Pneumatic Driving System Tool Package Includes:**

- Air Hammer Assembly
- Winch Pole Assembly
- Pull Down Winch Assembly
- Band Curling Tool
- Banding Dispenser
- Air Tensioner
- Air Crimp Sealer
- Manual Banding Shear
- Air Cutter
- Filter Regulator Lubricator
- (2 ea) 3/8" Tool Hose (25 ft. ea.)
- Nylon Ratchet Securing Strap

## **The PE500DWS Drop Weight Driving System**

may be operated using either a truck mounted or pole mounted capstan hoist. The drop weight driving system is recommended for hard driving soil conditions. The optional **CS2000 Choker Cable** and **DWB2000 Snatch Block** have a 2,000 lb. capacity and are rated for use with this system.



# PRS Engineering Worksheet

The LWS engineering staff will assist you in determining which standard PRS configuration will best suit your needs. Complete structural engineering analysis including foundation design is provided at no extra cost. Just fill in the requested information on this page along with a sketch of your current configuration and fax to LWS at **402-643-4374**. OR you may fill out this form on the web by going to [www.lwsinc.com](http://www.lwsinc.com).

**Please attach your standard drawing(s) which include the required information as shown below:**

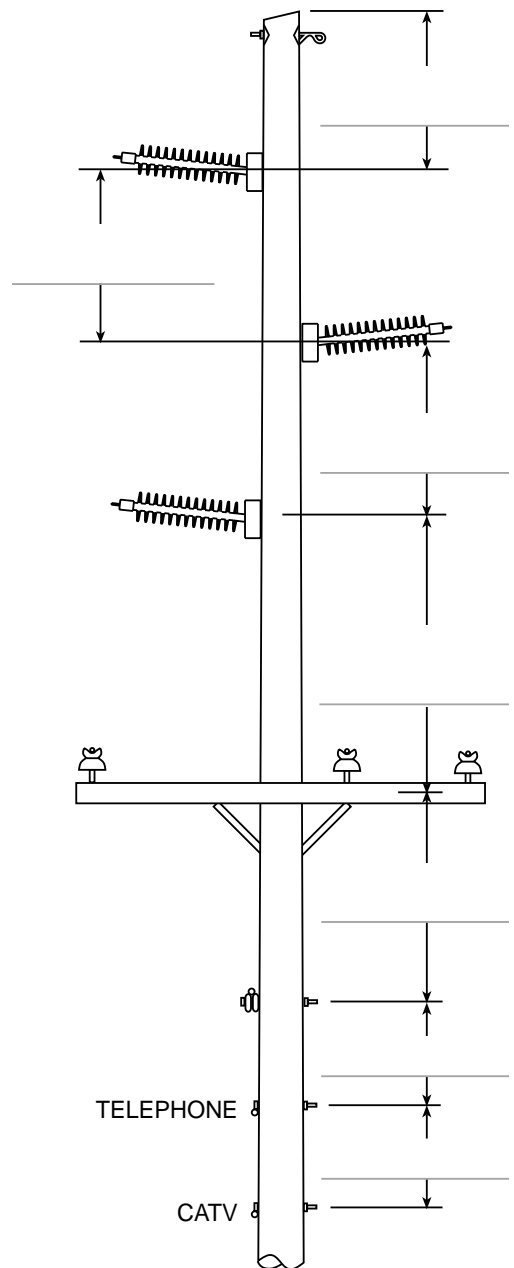

Construction Type \_\_\_\_\_

Line Voltage(s) \_\_\_\_\_

Number of Conductors \_\_\_\_\_

Conductor Size \_\_\_\_\_

Underbuild Conductor Size \_\_\_\_\_

Underbuild Number of Wires \_\_\_\_\_

Number of Neutral/Shield Wires \_\_\_\_\_

Cable TV \_\_\_ Diameter \_\_\_\_\_ No. of Wires \_\_\_\_\_

Telephone \_\_\_ Diameter \_\_\_\_\_ No. of Wires \_\_\_\_\_

Neutral/Shield Wire Size \_\_\_\_\_

Spans (feet) \_\_\_\_\_ to \_\_\_\_\_

Loading Conditions \_\_\_\_\_

Example - NESC Heavy Loading, Grade B Construction, Extreme Wind

Pole Height, Range \_\_\_\_\_ to \_\_\_\_\_

Pole Class \_\_\_\_\_ Soil Type \_\_\_\_\_

Age of Line \_\_\_\_\_ Leaners \_\_\_Yes \_\_\_No

Additional Comments:

---

---

---

---

# The LWS “Family of Steel”

Innovative, Patented Products Designed to Strengthen, Maximize and Extend the Life of the Electric Utility Infrastructure



## PoleEnforcer®

PATENT NO. 5,383,749

- **REINFORCE** existing poles with thin shell or “no shell” at the groundline
- Save thousands of dollars by reinforcing poles that others reject
- Repair & reinforce burnt and broken poles



## PHASERAISER®

PATENT NOS. 6,115,988 6,151,860

- **RAISE** existing structures to increase conductor clearances while the line **REMAINS IN SERVICE**
- Increase line capacity and revenues
- Increase conductor clearance an additional 3 to 20 feet
- Save many thousands of dollars by avoiding an outage
- Patented systems available for both single pole and H-frame structures



## PRS

**Pole Reclassification System®**

- **RECLASSIFY** existing poles up to 3 or more classes
- Eliminate the cost of expensive pole change outs
- Reinforce groundline strength
- Use in transmission or distribution applications



1327 285th Road  
Seward, NE 68434  
Phone 800-949-3526  
Fax 402-643-4374

**Laminated Wood Systems, Inc.**

[www.lwsinc.com](http://www.lwsinc.com)